

Installation Tutorials

Sensor Mounting Orientation

Date	2022/10/24
Author	Amir Baker
Verified	Dries Van Loon & Kareem Younis
Version	5



Table of Contents

1. Sensor Mounting	3
2. Sensor Orientation:.....	4
3. Mounting Location – Horizontal equipment:	5
4. Mounting Location – Vertical equipment:.....	6



1. Sensor Mounting

Also see guideline “3.1 Mounting Methods” for more detailed info on best practices on mounting the sensor.

The ideal way to mount the sensor on the equipment is by stud mount using the 1/4”28 stud and mount the sensor directly on equipment in pre-threaded hole using thread locker.



The next best option to mount the sensor on the equipment is to apply epoxy at the bottom of the magnet and place it on the equipment. The combination of magnet + epoxy ensures solid bond between the sensors and the equipment.

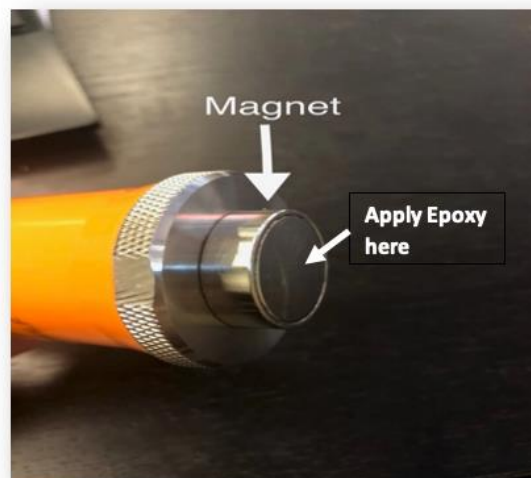
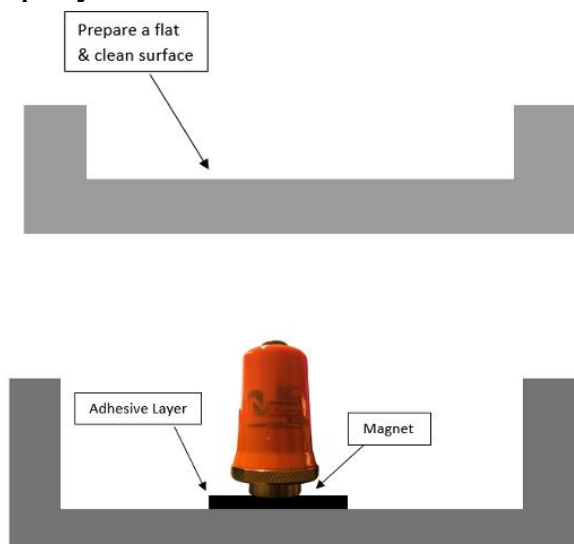



2. Sensor Orientation:

On the Sensor based the Z-X-Y orientation is displayed to assure



Z-Axis: Horizontal plane (In line with sensor axis)

Y-Axis: Vertical plane (Parallel with PCB)

X-Axis: Out of the plane (Perpendicular to the PCB face)



3. Mounting Location – Horizontal equipment:

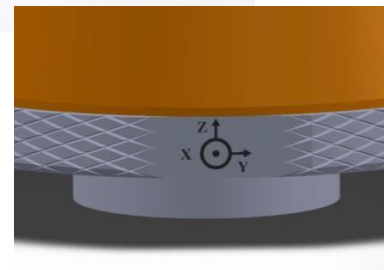
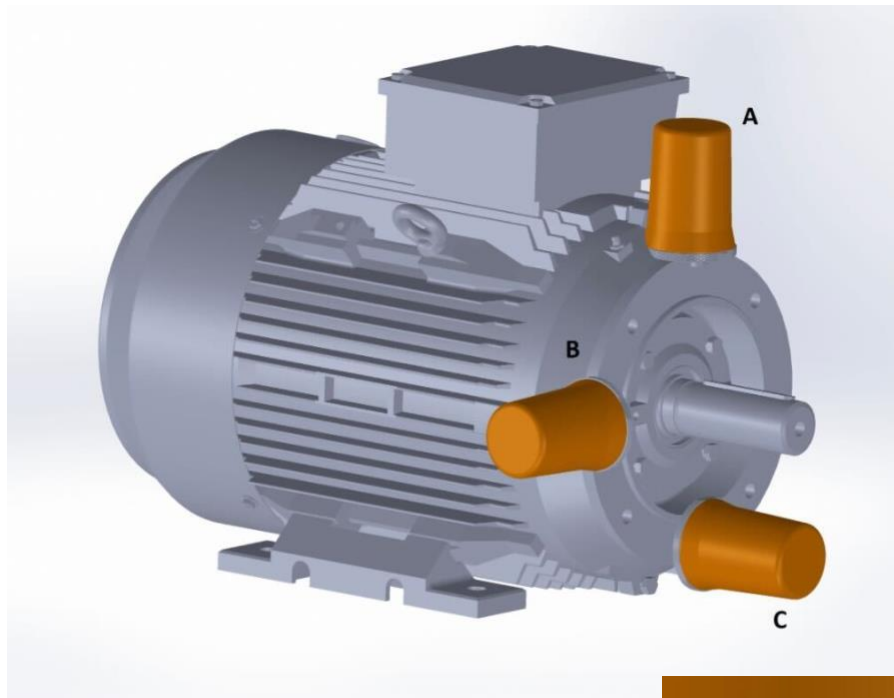

Horizontal Asset

- A) 1: Vertical mount, shaft aligned with Sensor X
2: Vertical mount, shaft aligned with Sensor Y
- B) 1: Horizontal mount, shaft aligned with Sensor X
2: Horizontal mount, shaft aligned with Sensor Y
- C) 1: Axial mount, Vertical (gravity) direction aligned with Sensor Y
2: Axial mount, Vertical (gravity) direction aligned with Sensor X



4. Mounting Location – Vertical equipment:

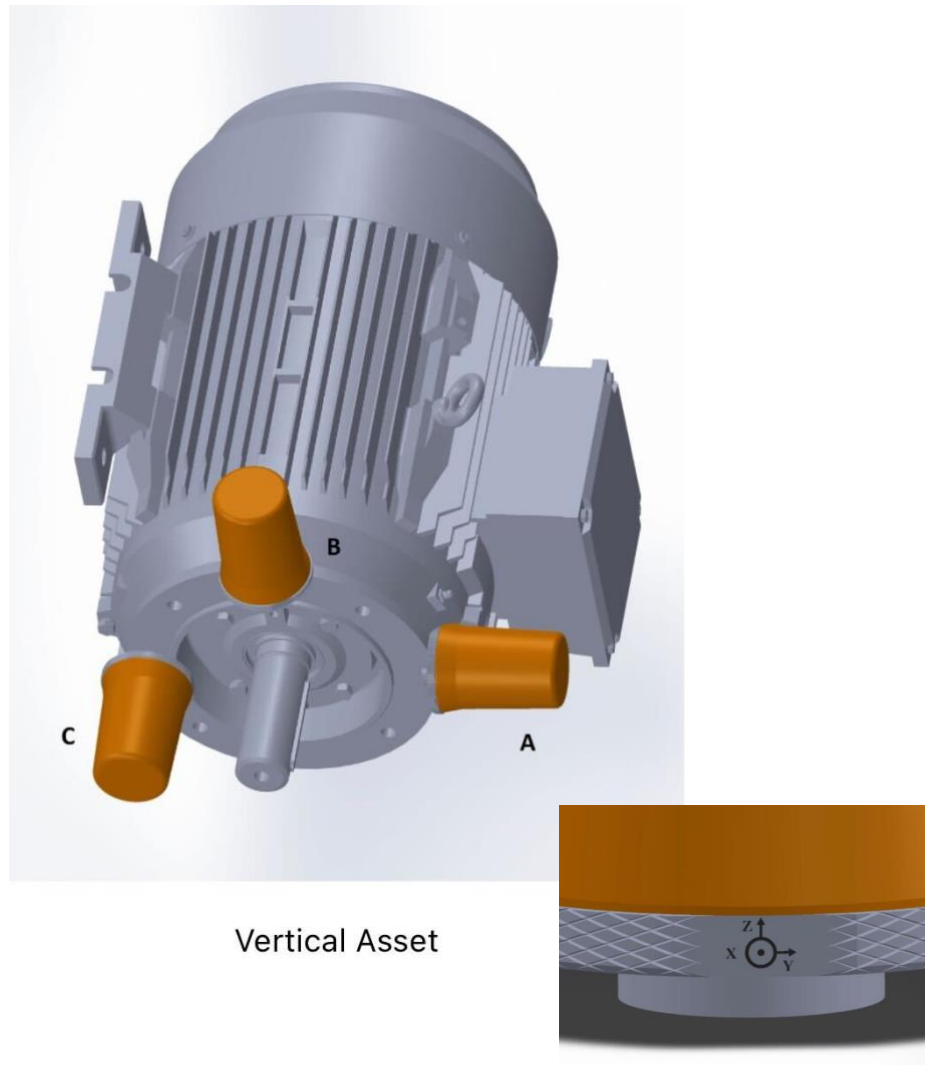

Vertical Asset

- A/B) 1: Radial mount, shaft aligned with Sensor Y
2: Radial mount, shaft aligned with Sensor X
- C) 1: Axial mount (X radial, Y, Radial)